

ADC-16

16-Bit Resolution
Analog Input Board

Functional Description

Keithley's ADC-16 is a low cost, 16-bit analog input board for ISA and EISA bus computers (IBM PC/XT/AT or compatibles). The heart of the ADC-16 is an integrating A/D converter which provides high accuracy (at up to 16 conversions/s) at low cost. Integrating A/D converters provide excellent precision and repeatability even in noisy environments.

ORDER	DESCRIPTION
ADC-16*	8-Channel 16-bit Analog Input board with Standard Software Package and ASO-ADC-16 (Advanced Software Option)
OPTIONS	See page 479 for descriptions of all accessories.
STA-EX8	8-Channel Expansion Accessory
STA-U	Screw Terminal Accessory Board
C1800	ADC-16 to STA-EX8 or STA-U Cable
MS-ADC-16*	Additional Hardware and Software Manual and Standard Software
TESTPOINT	TestPoint Software Package
* Software supplied on 3.5 inch disks.	

The board provides 8 differential channels at 16-bit resolution. The analog input range is jumper-selectable for +3.276V or +5V. An instrumentation amplifier with software programmable gain selects gains of 1, 10, or 100. Input autozeroing automatically eliminates input offset errors.

The ADC-16 also provides 5 TTL-compatible general-purpose digital outputs and two general-purpose TTL/CMOS compatible digital inputs. Two digital outputs drive two internal

form C relays on the ADC-16, and the contacts are brought out on the rear connector. These relays are used for a variety of switching and expansion applications. Three digital outputs can be used to control the optional STA-EX8 expansion multiplexers.

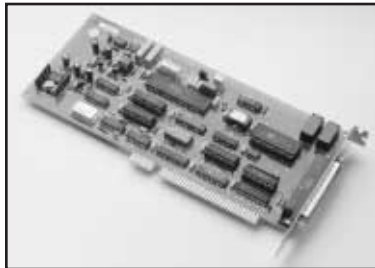

The ADC-16's high-precision current source has a compliance of -10V to +4V. This source can be used to directly excite resistance-based transducers such as RTDs.

Software

Included with the ADC-16 is the following software:

- ADC-16 Standard Software Package
- Advanced Software Option (ASO-ADC-16)

These two software packages have the following basic modules:

FEATURES

- 16-bit resolution
- 8 differential input channels
- Low noise, integrating A/D converter
- Expandable to 64 channels
- Onboard precision 1mA current source for sensor excitation
- ±5 or ±3.276V input ranges
- Programmable gains of 1, 10, or 100

APPLICATIONS

- Chromatography
- Temperature measurement
- Flow measurement
- Spectroscopy
- High accuracy data acquisition

Function Call Driver

The Function Call Driver provides high-level functions for use in your particular programming environment (e.g., QuickBASIC, C, Pascal). These functions provide access to all features and operations of the ADC-16 board. The driver handles all data acquisition functions and memory and buffer allocation. The function calls have intuitive names that describe the functions they perform.

Example Programs

Commented example programs illustrate how to program the ADC-16 in a variety of different modes using the Function Call Driver. These programs are provided in all languages supported by that software package.

Standard Software Package

The Standard Software Package provided with the ADC-16 includes the following:

- Function Call Driver compatible with BASICA, QBASIC, and QuickBASIC
- DOS-based panels for controlling the board without programming
- ADC-16 Installation and configuration program
- Example programs in BASIC
- Complete calibration routine

Pop-Up Control Panel

The Pop-Up Control Panel is a DOS-based terminate and stay resident (TSR) program which allows you to directly control the operation of the data acquisition board without writing a single line of code.

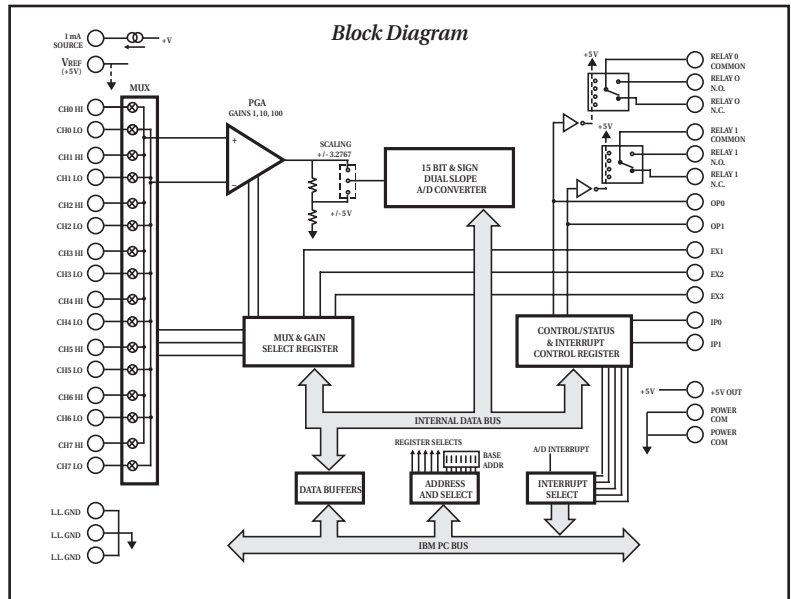

QUESTIONS?

1-800-552-1115 (U.S. only)

Call toll free for technical assistance, product support or ordering information, or visit our website at www.keithley.com.

ADC-16

Installation and Configuration Program

A single executable program shipped with every ADC-16 provides a complete guide to installation.

Advanced Software Option (ASO-ADC-16)

The ASO-ADC-16, which is included with each board, has the following capabilities:

- Function Call Drivers for Pascal, C/C++, Turbo Pascal (6.0), Visual Basic, and QuickC for Windows
- File I/O Command Driver for all languages
- Windows 3.X compatible Dynamic Link Library (DLL)
- Examples programs in all supported languages

File I/O Command Driver

The File I/O command driver is supplied as a loadable/unloadable DOS device driver and consists of a comprehensive set of English-based commands.

Accessories

The STA-EX8 8-channel expansion multiplexer option provides screw connections to all of the ADC-16 interface signals. It also adds 8 input channels. One STA-EX8 will provide a total of 15 channels, two provide 22 channels etc. A full complement of eight STA-EX8s will multiplex a total of 64 full differential channels. Applications not requiring the additional channels use the standard STA-U screw terminal board.

Configuration Guide

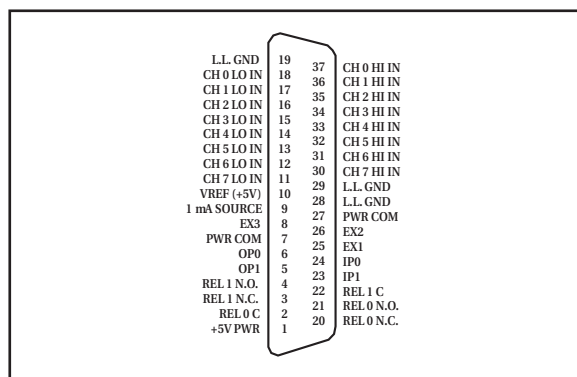
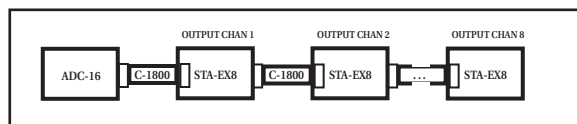

SPECIFICATIONS: ADC-16

A/D INPUTS

CHANNELS: 8 differential expandable to 64 with the use of 8 STA-EX8 boards.

INPUT RESOLUTION: 16 bits (15 + sign).

CODING: Sign + magnitude (binary).

INPUT RANGES: ±3.2768V, ±327.68mV, ±32.768mV, ±5V, ±500mV, ±50mV.

INPUT GAINS: 1, 10, or 100 (software selectable).

SAMPLE RATE: 16 samples/s.

INPUT SETTLING TIME: 50µs.

INPUT IMPEDANCE: Greater than 100MΩ.

INPUT BIAS CURRENT: 50nA max.

INPUT OFFSET:	Auto-zeroed	
	Gain = 1, 10	±1 LSB
	Gain = 100	±10µV
ACCURACY (OF FULL SCALE):	Gain = 1	±0.01% typ ±0.03% max
	Gain = 10	±0.05% typ ±0.10% max
	Gain = 100	±0.05% typ ±0.15% max
NOISE (TYPICAL):	Gain = 1	< ±1 bit rms
	Gain = 10	< ±1 bit rms
	Gain = 100	< ±3 bits rms
COMMON MODE REJECTION:	G=1	100dB typ, 80dB min
	G=10	110dB typ, 86dB min
	G=100	120dB typ, 92dB min

COMMON MODE RANGE: ±6V.

MAX INPUT VOLTAGE W/O DAMAGE (POWER ON): ±35VDC.

MAX INPUT VOLTAGE W/O DAMAGE (POWER OFF): ±20VDC.

DIGITAL I/O

DIGITAL INPUTS:

NO. OF INPUTS: 2, TTL/CMOS compatible.

LOGIC LEVELS: $V_{IL} = 0.8V$, $V_{IH} = 2.0V$.

$I_{IL} = -0.2mA$, $I_{IH} = 20µA @ 2.7V$.

DIGITAL OUTPUTS:

No. of Outputs: 5 TTL compatible.

Logic Levels: $V_{OL} = 0.5V$ max at 8.5mA.

$V_{OH} = 2.7V$ min @ -0.4mA.

RELAY OUTPUTS:

No. of Channels: 2 form C.

Max. Current: 2.0A, at 28V rms.

POWER REQUIREMENTS

+5V: 800mA typ, 1A max.

+12V: 25mA max.

-12V: 15mA max.

ENVIRONMENTAL

OPERATING TEMP: 0 to 70°C.

STORAGE TEMP: -25 to 85°C.

HUMIDITY: 0 to 95% non-condensing.

DIMENSIONS: 9.0in L × 4.25in H × 0.75in D
(22.9cm × 10.8cm × 1.9cm).

SPECIFICATIONS: STA-EX8

NUMBER OF INPUTS: 8 differential.

INPUT OFFSET: Auto-zeroed.

ACCURACY: 0.01 of full scale.

NOISE:

GAIN = 1: < ±1 bit rms.

GAIN = 10: < ±2 bit rms.

GAIN = 100: < ±15 bits rms.

INPUT IMPEDANCE: Greater than 100MΩ.

INPUT BIAS CURRENT: 50nA max.

COMMON MODE RANGE: ±6V.

MAX INPUT VOLTAGE W/O DAMAGE: ±35VDC (power on), ±20VDC (power off).

POWER REQUIREMENTS

+5V: 10mA typ, 100mA max.

ENVIRONMENTAL

OPERATING TEMP: 0 to 70°C.

STORAGE TEMP: -25 to 85°C.

HUMIDITY: 0 to 95% non-condensing.

DIMENSIONS: 5.2in by 6.7in by 2.3in (not including plastic enclosure).